

Table of Contents

1	Introduction.....	1
2	Layer concept	2
2.1	Layer-Enhancement (optional).....	5
2.2	Rules to the layer concept.....	7
2.3	Layer example	8
2.3.1Tool component rotationally symmetrical	8
2.3.2Tool component non rotationally symmetrical (Lathe tool)	11
2.3.3Tool combination rotationally symmetrical	15
2.3.4Tool combination non rotationally symmetrical (Lathe tool)	17
3	Data concept	18
3.1	Zero points and reference points	18
3.1.1Tool rotationally symmetrical.....	18
3.1.2Tool non rotationally symmetrical (Lathe tool).....	20
3.2	Rules for the data concept	23
3.3	Rules for the dimensioning of tool combinations.....	23
3.4	Dimensioning parameter	24

BMG (Betriebs-Mittel-Grafik/Production-Facility-Graphic) layer- und data concept

1 Introduction

As the **BMG (Betriebs-Mittel-Grafik/Production-Facility-Graphic)** layer- und data concept 1994 in a project with 8 industrial companies, 1 software distributor and the institute of research and development of the ISG – today Institute for Automation und Production technology at the INTERSTAATLICHEN HOCHSCHULE FÜR TECHNIK BUCHS NTB has been developed, it referred exclusively to 2D-Graphics. The main operational area has been the tool adjustment and NC-programming-systems, where the tool graphics have been used for 2D-Simulation. The PFG centre has been at MIT since then (i.e. 1994), where tool graphics of different tool companies have been converted to the BMG layer- and data concept and made available to the user.

During this time 3D-Simulation-Systems have been developed, which guarantee a simulation with collision check of complex cutting on multi axis NC-working centers from ISO-code 66025. With these systems it is possible to model complete machines with all aggregates and clamping jigs.

The collision check is not only carried out in the working area of a tool, i.e. the clamping jigs and cutting area, but covers all relevant moving parts of the machine.

To realize a 3D simulation, a machine has to be modelled, the cinematic attributes of all axis must be assigned, and with a special software, by processing the NC records of the ISO-code the virtual machining process is realized. This development has to be done for each NC-machine, whereas for every machining process the 3D volume of the workpiece, the clamping jigs and the tools have to be prepared. Most of the 3D-simulation systems have interfaces to the common 3D-CAD-systems, whereby 3D volumes of workpieces for example can be transferred. Otherwise the preparation of tools and clamping jigs in a 3D-size is relatively expensive, because existing 3D-graphics are inadequate. Hence more and more complete 3D tool-combinations are required. Until capable software tools for the efficient creation of 3D-tool-components are available, rotationally symmetrical tools are created as a compromise by rotating the half contour of a 2D tool graphic about the symmetric axis. But additional information like the direction of feed or the direction of cutting are missing here too. As the 3D-simulation systems proceed with stock removal, it must be differentiated between cutting and non cutting tool components. In the present BMG layer- and data concept this difference is taken into consideration. Also the data concept includes the rules of zero-points for non rotationally symmetrical tools (lathe tools).

Aspects for the future:

In a finished project new feature oriented solutions including the parametric to create 3D-production-facility-graphics automatically from advanced norm data have been realized.

2 Layer concept

The layer structure at the centre of BMG fulfils all the requirements for the presentation of tool components and complete tool combinations. First of all it applies to the tool adjustment, as information for the tool purchasing and tool management. For using the tool graphics in 3D simulation systems the required 3D CAD models are created by rotating the shell contour as a half contour about the symmetric axis of a 2D tool graphic. This solution is indeed limited to rotationally symmetrical tools. Lathe tools must be created in a 3D CAD system.

The contours of the contact areas of the tool components which become invisible on the assembly of the tool components are placed on the SK-layer. So it is warranted that these contours are not represented in tool combinations, because the view gets very complex. On the other hand it makes sense to show invisible holes for cooling liquid for example. Therefore layer 3 for example is used for the allocation of invisible lines for tool components and/or tool combinations and layer SK3 is reserved exclusively for tool components. The center line for tool components is placed on layer SK4 and is plotted about 10 – 15 mm over the cross line. If the same center line is used in the tool combination, the center lines of the tool components would overlap at the contact areas and a drawn through line would be shown. Therefore the center line for tool combinations is placed on layer 4. It can still be defined in the tool components but must start and end exactly between the left and the right cross line of the contour on layer 1 and may not be longer than the part of the component, which is shown in the combination (inserted length).

The dimensioning of the tool combination is placed on layer 2 or 2L. For drilling and milling tools, layer 2 is assigned. For lathe tools the dimensioning is placed on layer 2l, because the presentation here is turned through 180 degrees.

In 3D simulation systems for rotationally symmetrical tools additional layers CUT and NOCUT are needed. For the creation of a 3D tool combination the shell contour of the relevant geometry of the no cutting (NOCUT) and of the cutting part (CUT) of the tool component is rotated as a half contour. All other layers are blanked out at this moment. Most of the CAD systems require closed contours. The efficiency of the cutting tool component (CUT) can not be guaranteed in every case, because in some systems for example closed 3D objects are expected and concave sub-object are not allowed. This rule doesn't apply to non rotationally symmetrical tools (lathe tools).

The table on the following page shows the assignment of the single line types and colours to the layers. Furthermore the presentation of the example of layers offers detailed information about the spreading of the single layer.

BMG (Betriebs-Mittel-Grafik/Production-Facility-Graphic) layer- und data concept

BMG layer concept:

layer	format	line type	colour	
1	Contour	—————	cyan	≡≡≡
2	Dimension milling	↔ 60.0 ↔	white	≡≡≡
2L	Dimension turning	↔ 0.09 ↔	white	≡≡≡
3	Extension line	-----	red	≡≡≡
4	Center line	- - - - -	yellow	
5	Frame	—————	white	≡≡≡
6	Text	—————	blue	≡≡≡
CUT	Contour	—————	red	≡≡≡
NOCUT	Contour	—————	white	≡≡≡
SK1	SK1 Contour	—————	cyan	≡≡≡
SK2	SK2 dimension	↔ 60.0 ↔	white	≡≡≡
SK3	SK3 extension line	-----	red	≡≡≡
SK4	SK4 center line	- - - - -	yellow	≡≡≡
SK6	SK6 Text	—————	blue	≡≡≡











||||| layer for tool combination
≡≡≡ layer for tool components

The frame is not required for further processing of the tool graphic in tool management and NC-programming systems. For information it is recommended placing the frame for the drawing head on layer 5.

The layer colours correspond only to the presentation on a screen. For an output on a plotter or printer the colours are represented as shown on the following page.

BMG (Betriebs-Mittel-Grafik/Production-Facility-Graphic) layer- und data concept

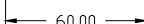
The line types, description and colours of the single layers are shown in the following table:





	Format	Layer
	Contour	1
	Dimension milling	2
	Dimension turning	2L
	Extension line	3
	Center	4
	Frame	5
	Text	6
	SK1 contour	SK1
	SK2 dimension	SK2
	SK3 extension line	SK3
	SK4 center line	SK4
	SK6 text	SK6

BMG (Betriebs-Mittel-Grafik/Production-Facility-Graphic) layer- und data concept

2.1 Layer-Enhancement (optional)

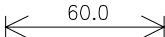
In the environment of different workgroups of the VDMA the necessity arose for defining further layers for tool graphics. Since these additional layers are not required for the design of tool graphics in tool management systems (2D) as well as in applications of simulation systems (3D), they only act as enhancements for the assignment of further detailed information.

Additional layers for the graphic:

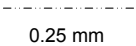
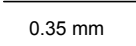
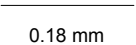
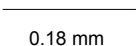
layer	format	line type	colour
SKVIEW1	SK contour side, top and bottom view only		light blue
SKVIEW2	SK dimension side, top and bottom view only		white
SKVIEW3	SK extension line side, top and bottom view only		red
SKVIEW4	SK center line side, top and bottom view only		yellow
SKVIEW6	SK text side, top and bottom view only		dark blue
INFWKP	Geometry of the work-piece		orange
INFTEXT	Additional information e.g. position of the tool in the revolver, information text not belonging to the tool		blue
INFMAINVIEW	Expansion of the main graphic (TDM) max. horizontal and vertical lines		grey
INFTOTAL	Expansion of the whole drawing without frame max. horizontal and vertical lines		grey

BMG (Betriebs-Mittel-Grafik/Production-Facility-Graphic) layer- und data concept

Additional layers for multilingualism:

Layer	Format	Language
Layer 51	Text in the drawing frame	German
Layer 52	Text in the drawing frame	English
Layer 53	Text in the drawing frame	French
<i>Layer 54 - 59</i>	<i>Text in the drawing frame</i>	<i>reserved for further languages</i>
Layer 61	Inscription of the tool-combination	German
Layer 62	Inscription of the tool-combination	English
Layer 63	Inscription of the tool-combination	French
<i>Layer 64 - 69</i>	<i>Inscription of the tool-combination</i>	<i>reserved for further languages</i>
Layer SK61	Inscription of the tool-component	German
Layer SK62	Inscription of the tool-component	English
Layer SK63	Inscription of the tool-component	French
<i>Layer SK64 - SK69</i>	<i>Inscription of the tool-component</i>	<i>reserved for further languages</i>

2.2 Rules to the layer concept

The different contours are assigned to the layers as previously defined. For use in tool management, NC-programming- and simulation-systems the additional layers (Section 2.1 Layer-enhancement) are ignored.

For the layer structure see the following rules:

1. outside contour, with tool combination visible (e.g. Layer 1)
2. outside contour of the contact interface, with tool combination invisible (e.g. Layer SK1)
3. inside contour (invisible), shown only with tool component (e.g. Layer SK3)
4. inside contour (invisible), shown with tool component and tool combination (e.g. holes for cooling liquid Layer 3)
5. shell contour non cutting for presentation in simulation systems (Layer NOCUT)
6. shell contour cutting for presentation in simulation systems (Layer CUT)
7. dimensioning of the tool component (e.g. Layer SK2).
(parameters for dimensioning see chapter 3.4, page 22)
8. dimensions for representation in tool combinations as well (e.g. Layer 2)
(parameters for dimensioning see chapter 3.4, page 22)
9. center line of the tool component (Layer SK4)
10. center line of the tool combination (Layer 4, length = length of insert)
11. texts for tool component (Layer SK6)
12. texts for tool combination (Layer 6)

2.3 Layer example

2.3.1 Tool component rotationally symmetrical

← **Formatiert:** Nummerierung und Aufzählungszeichen

← **Formatiert:** Nummerierung und Aufzählungszeichen

All layers

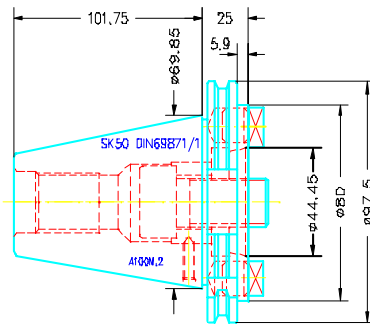

Layer 1

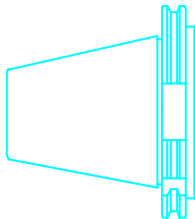

Layer 2

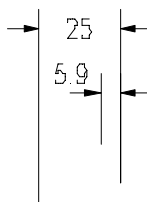

Layer 4



Layer 6

SK50 DIN69871/1

A100M.2

Layer NOCUT

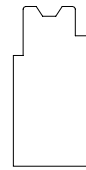

Layer SK1



Layer SK2

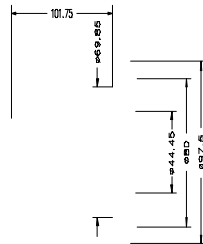

Layer SK3

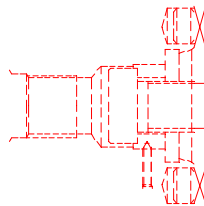

Layer SK4



BMG (Betriebs-Mittel-Grafik/Production-Facility-Graphic) layer- und data concept

All layers

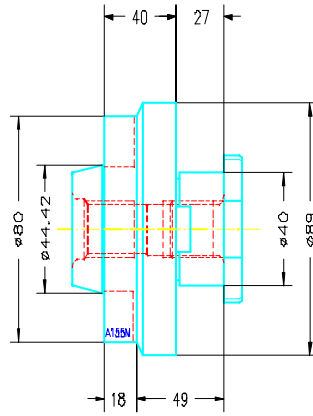

Layer 1

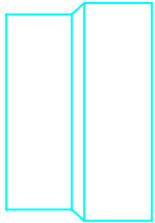

Layer 2

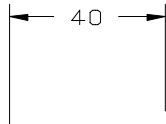

Layer 4



Layer 6

Layer NOCUT

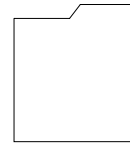

Layer SK1

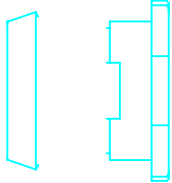

Layer SK2

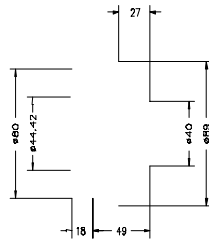

Layer SK3

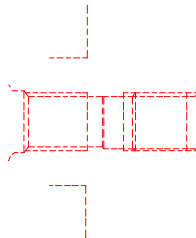

Layer SK4



BMG (Betriebs-Mittel-Grafik/Production-Facility-Graphic) layer- und data concept

All layers

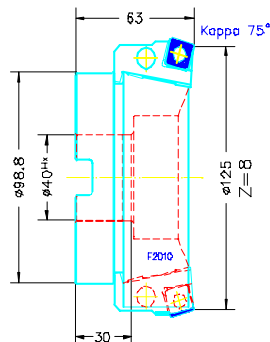

Layer 1

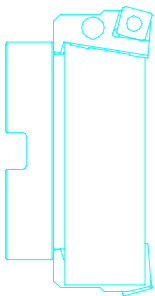

Layer 2

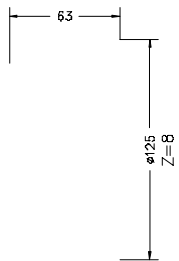

Layer 4

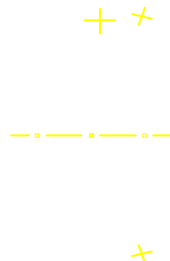

Layer 6



Layer NOCUT

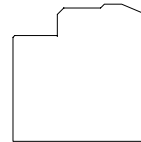

Layer CUT



Layer SK2

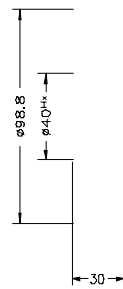

Layer SK3

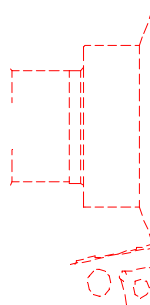

Layer SK4

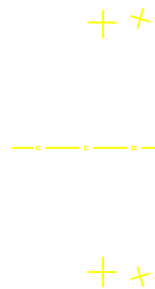

BMG (Betriebs-Mittel-Grafik/Production-Facility-Graphic) layer- und data concept

2.3.2 Tool component non rotationally symmetrical (Lathe tool)

← **Formatiert:** Nummerierung und Aufzählungszeichen

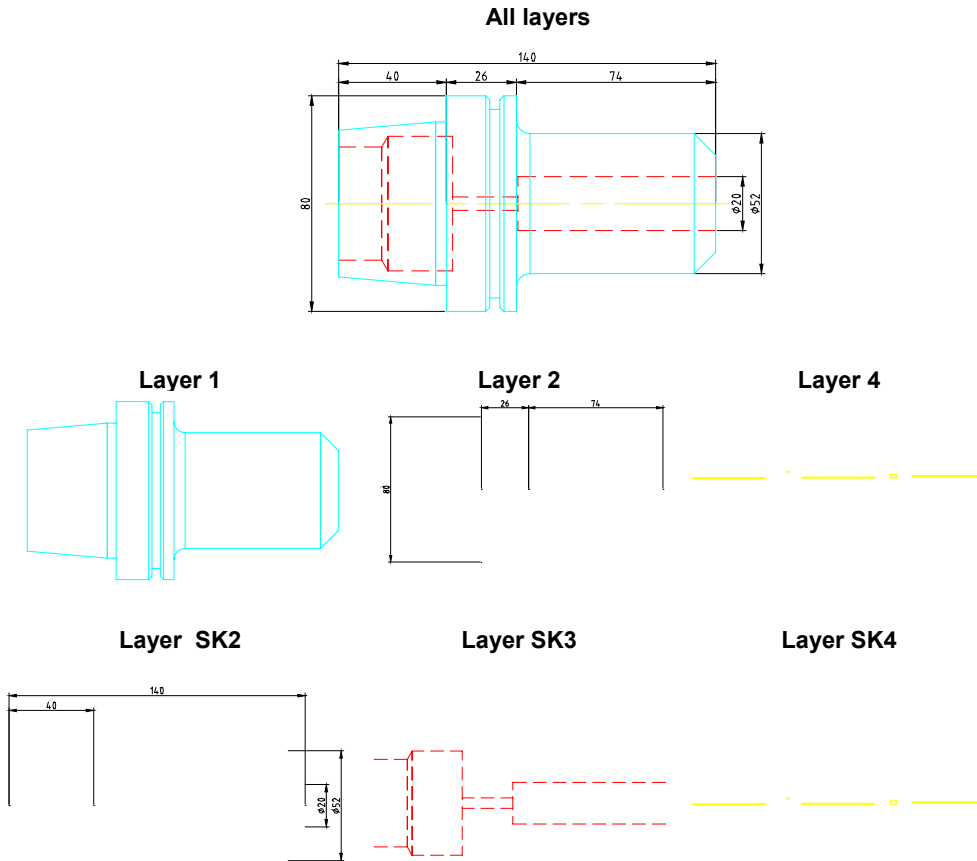

BMG (Betriebs-Mittel-Grafik/Production-Facility-Graphic) layer- und data concept

All layers

A20Q-STFCR11
2D093847

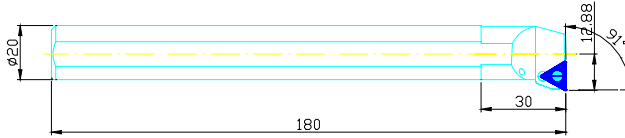

Layer 1

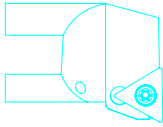

Layer 2L

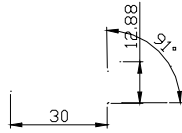

Layer 4



Layer 6



Layer SK1



Layer SK2



Layer SK4



Layer SK6

A20Q-STFCR11
2D093847

BMG (Betriebs-Mittel-Grafik/Production-Facility-Graphic) layer- und data concept

All layers

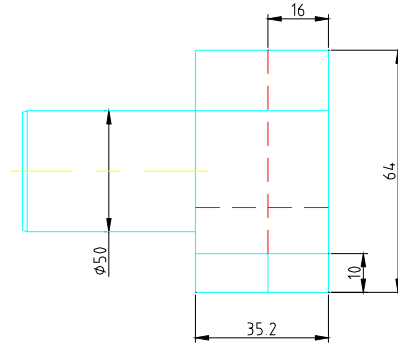

Layer 1

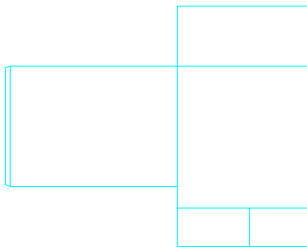

Layer 2



Layer 4



Layer SK2

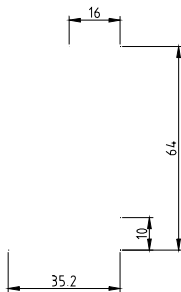

Layer SK3



Layer SK4



BMG (Betriebs-Mittel-Grafik/Production-Facility-Graphic) layer- und data concept

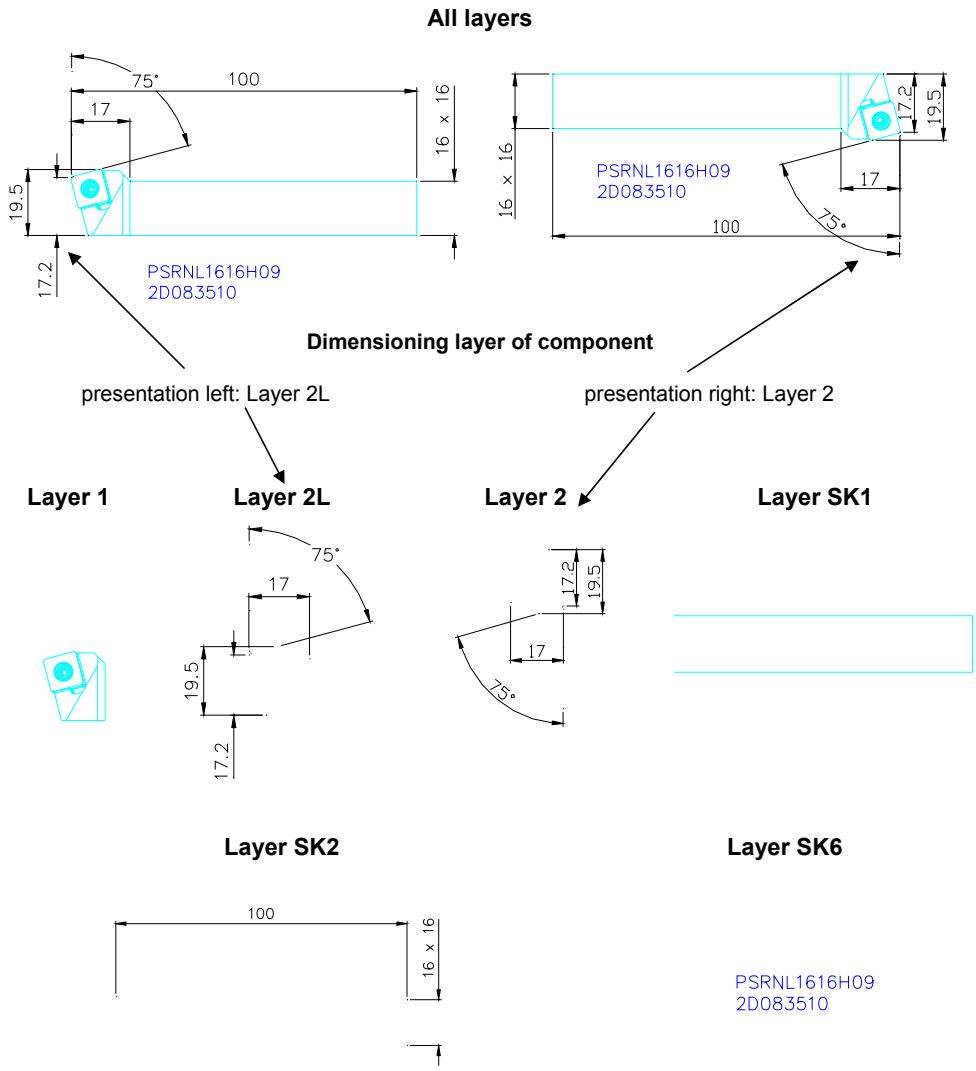

BMG (Betriebs-Mittel-Grafik/Production-Facility-Graphic) layer- und data concept

2.3.3 Tool combination rotationally symmetrical

← **Formatiert:** Nummerierung und Aufzählungszeichen

Layer 1 - 6

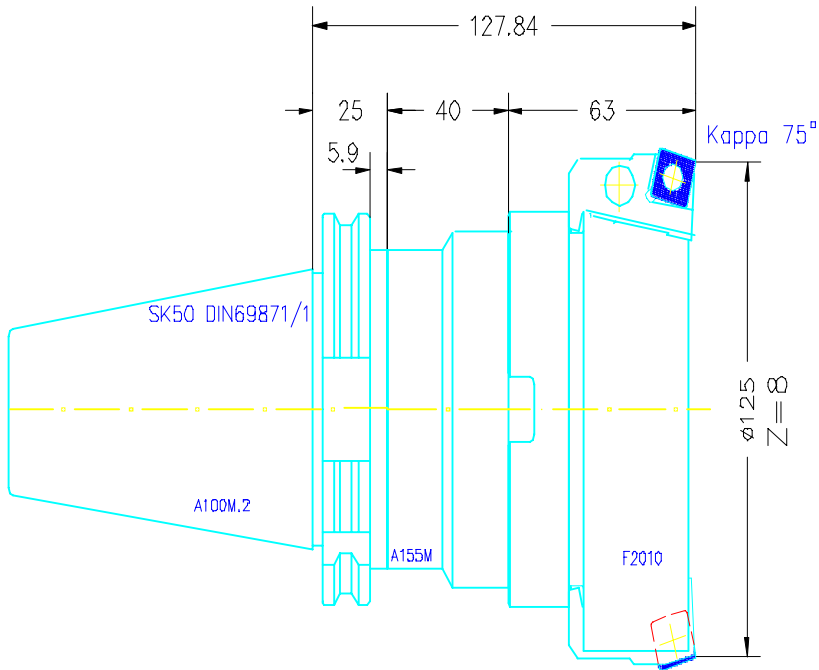

Layer NOCUT and CUT

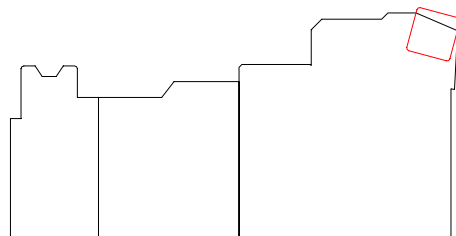

The shell contours of the single tool components of rotationally symmetrical tools must be closed and are used as shown as 2D-graphic to create a 3D-tool combination.

BMG (Betriebs-Mittel-Grafik/Production-Facility-Graphic) layer- und data concept

3D tool combination

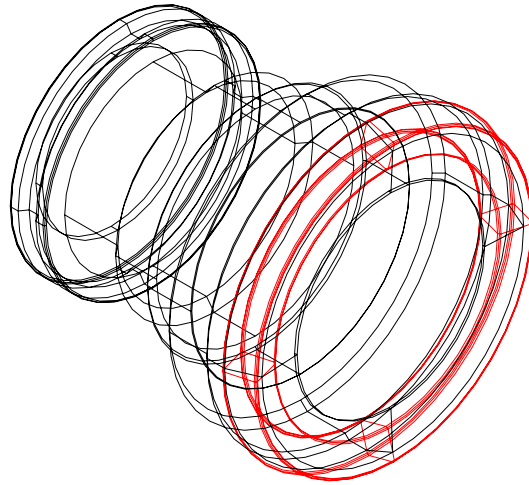

After development of a tool combination the 3D volume for the simulation will be built by rotating the shell contour of the single tool components.

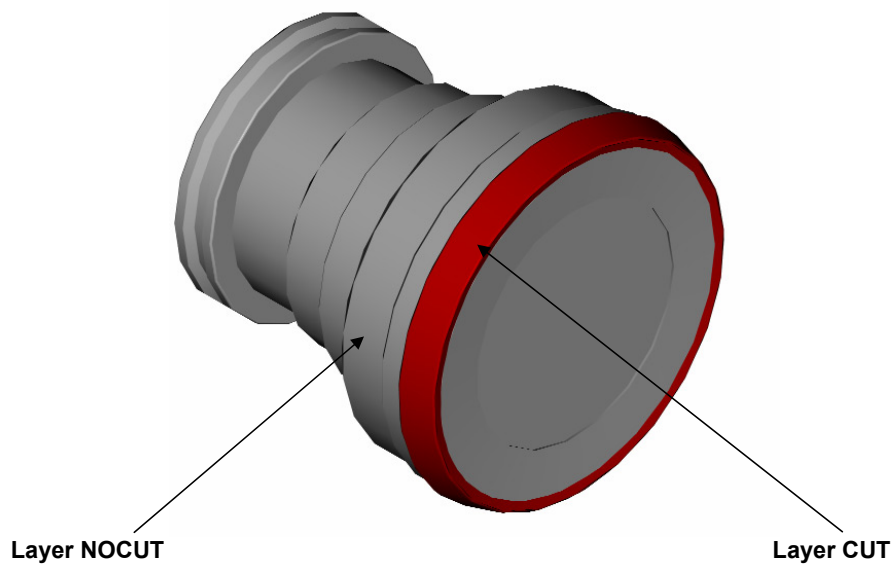

BMG (Betriebs-Mittel-Grafik/Production-Facility-Graphic) layer- und data concept

2.3.4 Tool combination non rotationally symmetrical (Lathe tool)

← -- -- **Formatiert:** Nummerierung und Aufzählungszeichen

Lathe tool inside

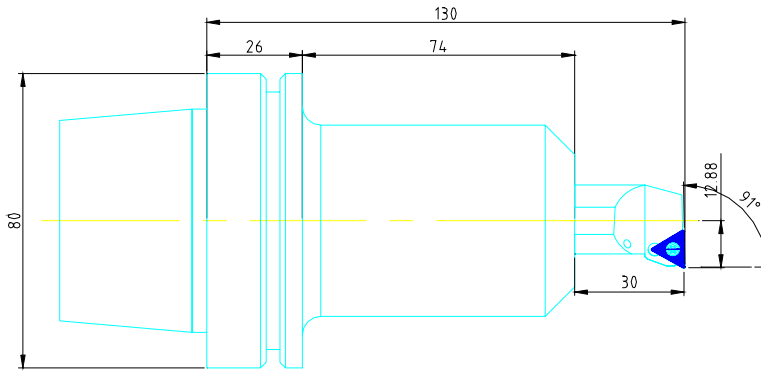

Lathe tool outside

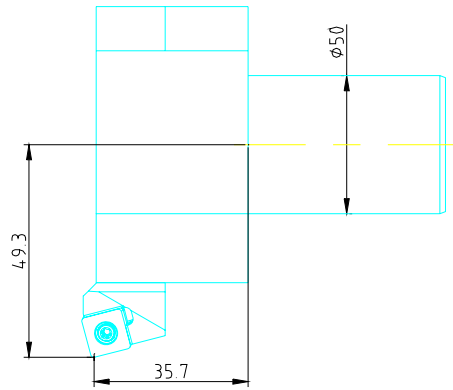

3 Data concept

3.1 Zero points and reference points

3.1.1 Tool rotationally symmetrical

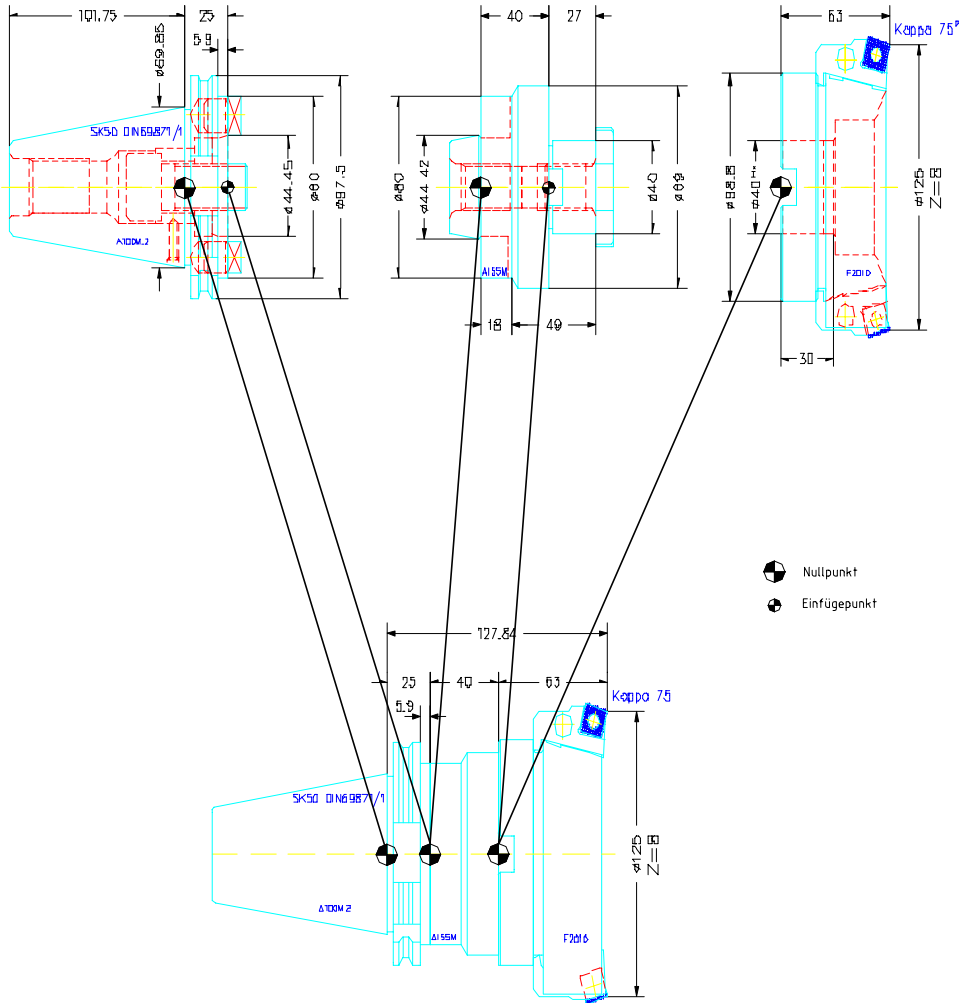

BMG (Betriebs-Mittel-Grafik/Production-Facility-Graphic) layer- und data concept

A simple representation here again of the position of the drawing zero point and the length of insert of the reference point of tool components.

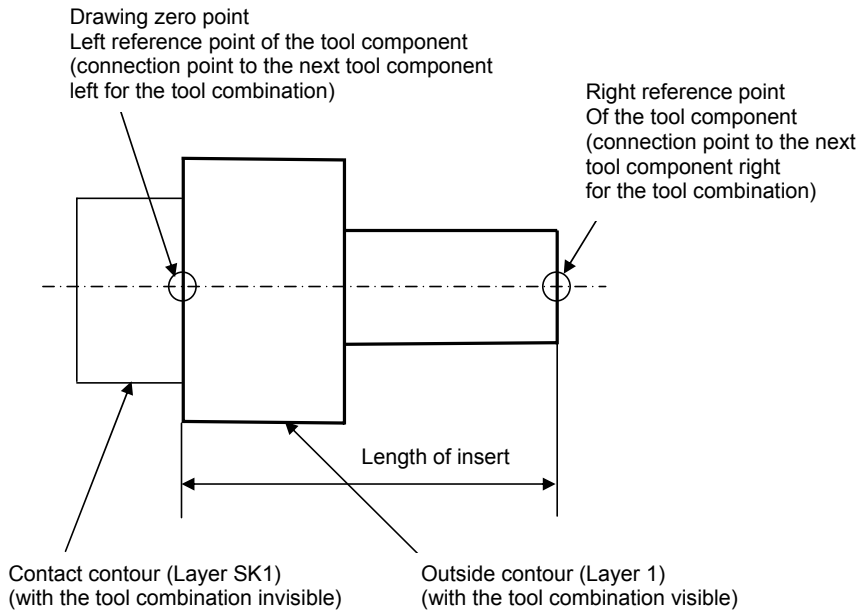

3.1.2 Tool non rotationally symmetrical (Lathe tool)

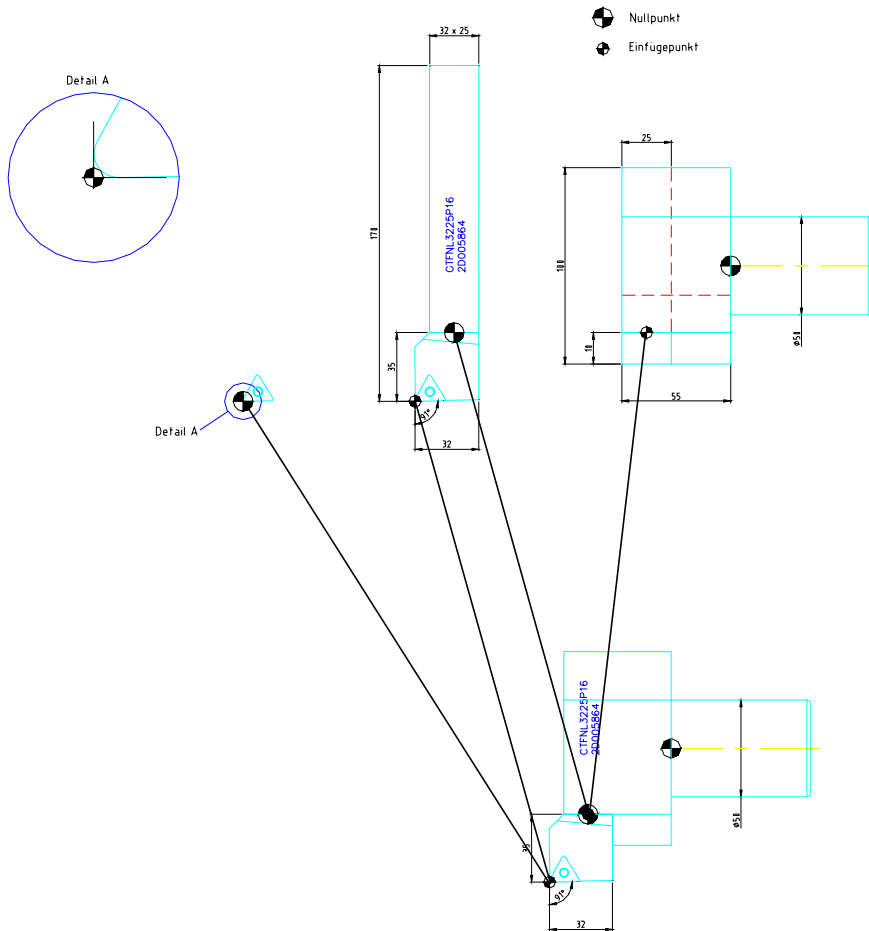

The zero point of the insert is placed in the theoretic intersection of the adjusting measurements (L + Q) of the tool combination

BMG (Betriebs-Mittel-Grafik/Production-Facility-Graphic) layer- und data concept

Further examples of the zero point position by inserts:

Turning tool symmetric

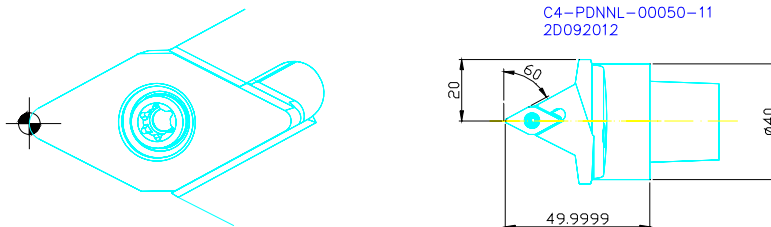

Recessing tool

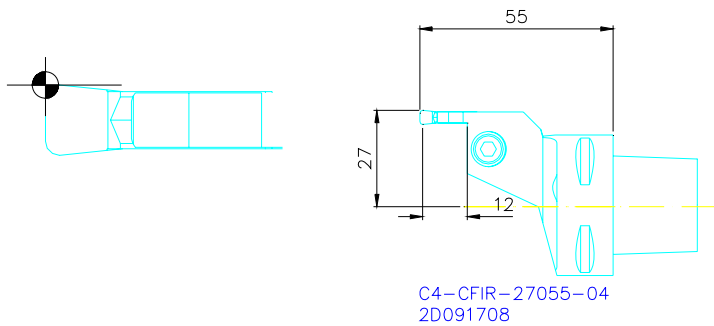

Position of the zero point of the left corner

round tool

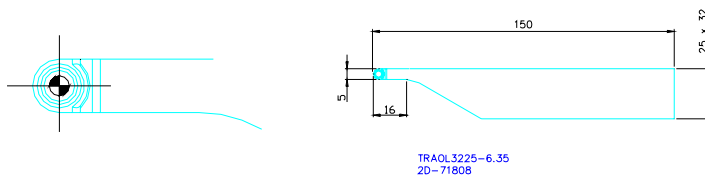

position of the zero point differing from the insert center

BMG (Betriebs-Mittel-Grafik/Production-Facility-Graphic) layer- und data concept

The position of zero points and connection points of lathe tools are recommendations from experiences with tool management systems (i.e. TDM, WinTool). The definition of distance in X-, Y- and Z direction from the zero point specifies the position of the connection point. The position of the zero point with lathe tools in the center of the shank makes sense therefore, because the free length exists in the information of a tool catalogue. (The position of the zero point at the end of the shank is unfavourable, because the shank length can be variable with different tool producers). The zero point of the insert is placed in the theoretic intersection of the adjusting measurements (L + Q) of the tool combination, on recessing tools at the left corner.

Exception: round insert. (The position of the zero point in the center of the insert is unfavourable, excepted round inserts, because usually the exact position is not indicated in the tool catalogue).

The graphic of a tool component has to be represented so, that the zero point is in the same position as the user coordinate system. The insert point is not defined in the graphic. It results of the distance of the X-, Y- and Z direction from the zero point and possible additional moving vectors, which have to be calculated and defined in each particular execution.

Because of many the possibilities of variations by non rotationally symmetrical tool combinations (lathe tools), additional data as supplementary information for a proper graphical presentation used in tool management systems are required.

Which are:

for tool components

- distance from zero point to the insert point of the next component

for tool combinations:

- the insert position of each component in the cartesian coordinate system (angle)
- the insert position of lathe tools normal or overhead
- the move vector of the insert for left and right recessing tools.
- the move vector of the outstanding length or width

BMG (Betriebs-Mittel-Grafik/Production-Facility-Graphic) layer- und data concept

3.2 Rules for the data concept

For graphic data of the tool components the following rules apply:

- The zero point of rotationally symmetrical tool components is positioned at the intersection of the center line and the left end face, visible in the tool combination (layer 1).
- The inserted length and the collision diameter of the single tool component must be defined in the tool combination. The distance of the dimension line for the length from the center line is 75 mm with rotationally symmetrical tools. If the tool radius \Rightarrow 60 mm, the distance of the length dimension extends at intervals of 15 mm. It guarantees that the dimensional lengths of all tool components in a tool combination are represented on the same level.
- A drawing frame can be represented on a separate layer if required (layer 5).

3.3 Rules for the dimensioning of tool combinations

Tool combinations are to be dimensioned by the following rules:

- Total length and cross dimension (only by non rotationally symmetrical tools – lathe tools) from the zero point of the tool holder in the machine spindle to the top of the cutter.
- All inserted lengths of single rotationally symmetrical tool components (distance 75 mm to the center line or about every 15 mm more)
- If the diameter of the cutting tool is not the largest, the larger collision diameters of further tool components should be dimensioned in the tool combination.

These rules are made clear in the layer example.

3.4 Dimensioning parameter

For the style of dimensioning in AutoCAD the following parameter definitions are used:

DIMALT	Off	Option of alternative units
DIMALTD	2	decimal place for alternative units
DIMALTF	25.40	conversion factor for alternative units
DIMALTTD	2	decimal place for alternative tolerance
DIMALTTZ	0	suppress zeros at alternative tolerances
DIMINUT	2	alternative units
DIMALTZ	0	eliminate zeros at alternative units
DIMAPOST		prefix and suffix for alternative text
DIMASO	On	generate associative dimensioning
DIMASZ	4.57	arrow length
DIMAUNIT	0	angle unit
DIMBLK		name of arrow block
DIMBLK1		name of the first arrow block
DIMBLK2		name of the second arrow block
DIMCEN	0.09	size of the center point
DIMCLRD		color of the dimension- and guide line
DIMCLRE		color of the subsidiary line
DIMCLRT		color of the dimension text
DIMDEC	2	decimal places
DIMDLE	0.00	extension of the dimension line
DIMDLI	0.38	distance of the dimension line
DIMEXE	5.00	extension of the subsidiary line above the dimension line
DIMEXO	0.00	distance of the subsidiary line
DIMFIT	3	adjusting text
DIMGAP	2.30	distance of the dimension line from text
DIMJUST	0	text orientation according to the dimension line
DIMLFAC	1.00	scale factor for linear units
DIMLIM	Off	generating dimensioning limits
DIMPOST		prefix and suffix for dimension text
DIMRND	0.00	rounding-off value
DIMSAH	Off	separate arrow blocks
DIMSCALE	0.00	general scale factor
DIMSD1	Off	suppressing the first dimension line
DIMSD2	Off	suppressing the second dimension line

BMG (Betriebs-Mittel-Grafik/Production-Facility-Graphic) layer- und data concept

DIMSE1	Off	suppressing the first subsidiary line
DIMSE2	Off	suppressing the second subsidiary line
DIMSHO	On	updating of dimensioning by pulling
DIMSOXD	Off	suppressing dimension line outside of the subsidiary line
DIMSTYL		current style of dimensioning (write protected)
DIMTAD	1	placing text above the dimension line
DIMTDEC	4	decimal places for tolerance
DIMTFAC	1.00	tolerance at scaling of the text size
DIMTIH	Off	text inside of subsidiary lines is horizontal
DIMTIX	Off	text inside of subsidiary lines
DIMTM	0.00	minus tolerance
DIMTOFL	Off	dimension line between subsidiary lines
DIMTOH	Off	text outside horizontal
DIMTOL	Off	tolerance of dimensions
DIMTOLJ	1	vertical orientation of the tolerance
DIMTP	0.00	plus tolerance
DIMTSZ	0.00	length of line
DIMTVP	0.00	vertical text position
DIMTXSTY		style of text
DIMTXT	4.5	height of text
DIMTZIN	0	suppressing zeros at tolerance
DIMUNIT	2	unit
DIMUPT	Off	text positioned by user
DIMZIN	8	suppressing zero